

Technical data sheet

**Model TL**  
**for inward/outward opening doors**

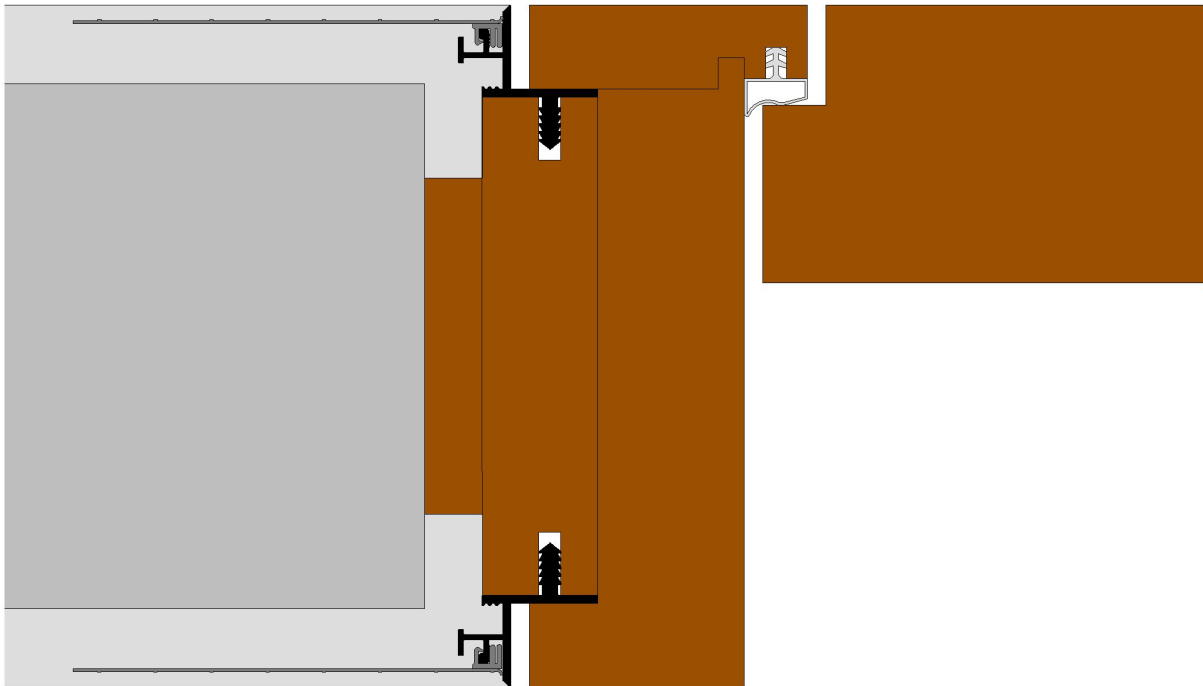

**Index**

Profile detail..... 2

Recommendations..... 3

    Suitable hinges..... 3

    Suitable closing panels..... 3

    Suitable seals..... 3

## Profile detail

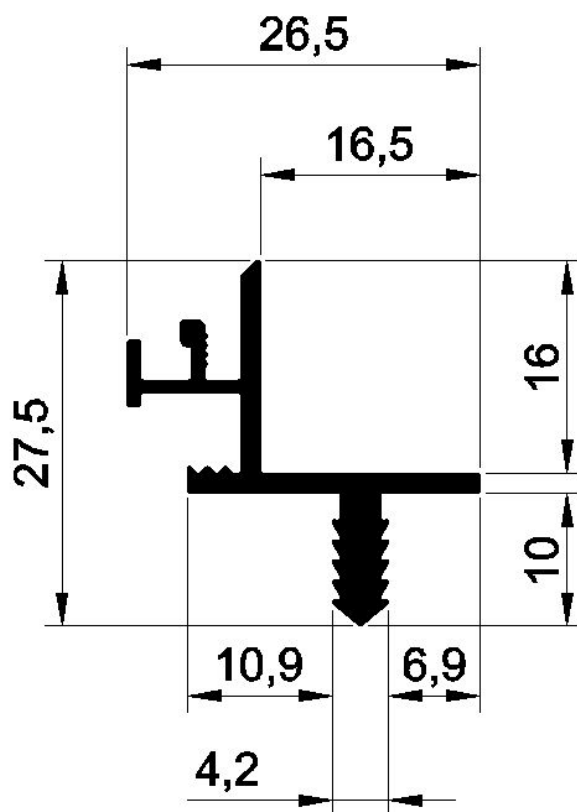

### Model TL

Suitable for solid and dry construction

Description	Item number	Standard lengths*
TL	10110-11	1100 mm
TL	10110-22	2200 mm
TL	10110-27	2750 mm
TL	10110-33	3300 mm
TL	10110-55	5500 mm

\*Special lengths on request.

Suitable for solid and dry construction

This profile system is push-fitted onto grooves in the frame linings prior to installing a finished timber door frame, to create the perfect shadow gap outline, and eliminate the need for architraves. The snap-in mesh ensures no plaster cracks between wall and frame. Suits standard or floor-to-ceiling doors.

## Recommendations

On the basis of detailed tests and long-term experiences our technical office has prepared a recommendation list regarding the selection of hinges, closing panels and seals. This lists are practical guidelines and non exhaustive.

<b>Suitable hinges</b>	
<i>Producer</i>	<i>Website</i>
Simonswerk GmbH	<a href="http://www.simonswerk.com">www.simonswerk.com</a>
Bartels-Systembeschläge GmbH	<a href="http://www.basyshome.com">www.basyshome.com</a>
Krone Koblenz SpA	<a href="http://www.k-group.com">www.k-group.com</a>

<b>Suitable closing panels</b>	
<i>Producer</i>	<i>Website</i>
Bonaiti Serrature SpA	<a href="http://www.bonaiti.it">www.bonaiti.it</a>
Kaba GmbH	<a href="http://www.kaba.de">www.kaba.de</a>
Alban Giacomo SpA	<a href="http://www.agb.it">www.agb.it</a>
KFV Karl Fliether GmbH & Co. Kg	<a href="http://www.kfv.de">www.kfv.de</a>

<b>Suitable seals</b>	
<i>Producer</i>	<i>Website</i>
Helmut Goll GmbH	<a href="http://www.helmutgoll.com">www.helmutgoll.com</a>
Deventer Profile GmbH	<a href="http://www.deventer-profile.com">www.deventer-profile.com</a>
Primo Profile GmbH	<a href="http://www.primo.com">www.primo.com</a>
Schlegel GmbH	<a href="http://www.schlegel.com">www.schlegel.com</a>

We guarantee for a high quality of our products. Our processing guidelines are based on tests and practical experiences; they are only indication without assurance of properties, we have no influence on condition of construction sites and the realizations of the works

Country specific regulations, which consist on regional standards, building regulations, processing and industrial guidelines, can guide to specific processing recommendations.